

In the best of all worlds, independent networks would be totally independent with separate servers, separate routers, separate switches and separate fibers. However, this is not always possible. In the network-centric world we live in, it is becoming increasingly desirable to support multiple independent networks on the same fiber infrastructure, albeit at different times.

### Create

For US Government network administrators this means not only supporting Internet, NIPRNet and SIPRNet on separate fibers within their networks, but rapidly, flexibly and securely reprovisioning which network is carried on any particular fiber at any particular time.

### Monitor

As a small scale example, consider a facility with a mixture of offices and conference rooms. Flexible use of the facility dictates that different networks be available in different offices based on the present occupant's clearance level. In addition, the network(s) available in any one conference room will vary depending on the nature of the meeting being held and the security classification of the participants. This becomes even more involved when you consider the possibility of meetings in which the chair of the meeting has requirements for (and is qualified for) access to a higher security network than the other participants. Different networks would need to be delivered to different seats in the conference room.

### Reconfigure

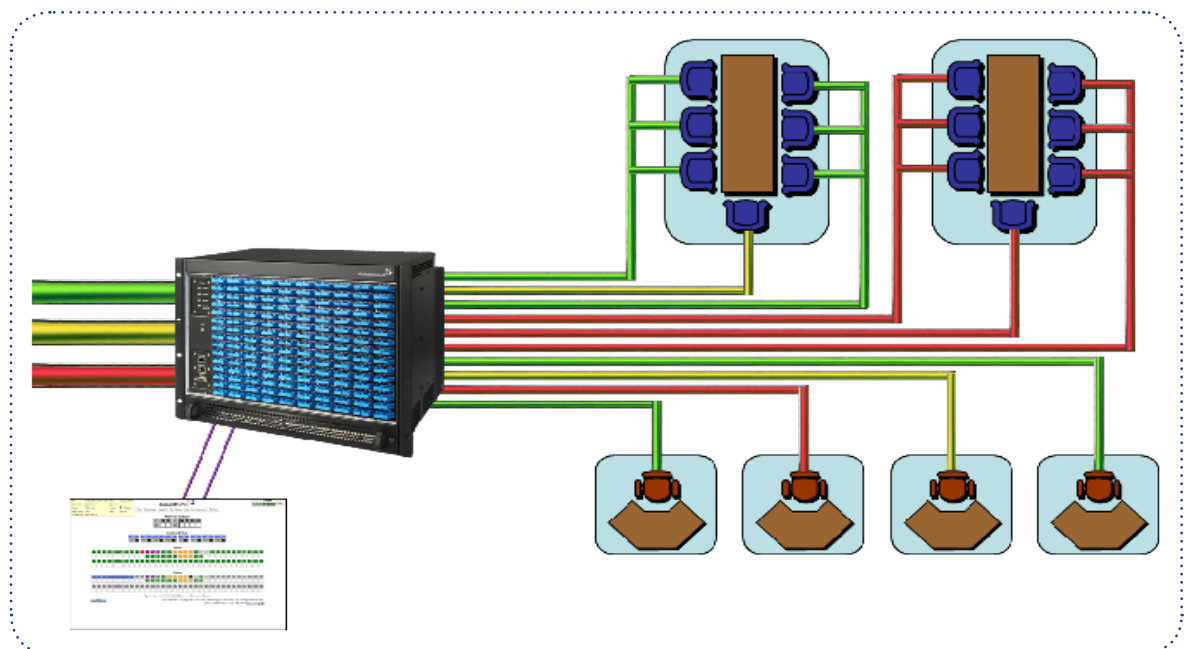

The functionality required in this environment is that of a crossconnect. Any network fiber needs to be connected to any terminal site. While this functionality could be supplied by electronic switching, there are a number of difficult problems which must be dealt with when introducing new electronics into these secure networks and especially when the electronics span multiple secure networks.

Purely Optical, photonic switching with the Glimmerglass Intelligent Optical System is a much better solution.

### Photonic Solution

The Glimmerglass Intelligent Optical System brings the following advantages to infrastructure supporting multiple secure networks:

#### No emissions

Reconfigure light paths without looking at the bits. No OEO conversions mean no radiated emissions.

#### Hands off operation

Eliminate the need to physically connect and disconnect fibers. This eliminates a major source of human error, fiber damage or contamination.

#### No crosstalk

Virtually eliminate crosstalk between fibers and thus between networks.

#### Clear channels

Support any data rate and protocol and virtually any wavelength. The light paths through switch do not interact with each other. Thus, there is no need to change line cards when rates or encryption methods change.

#### Photonic monitoring

Continuously monitor optical signal power for all light paths. The addition of fiber taps with a photonic switch for tap selection enables non-intrusive higher layer monitoring.

### Conclusion

The Glimmerglass Intelligent Optical Systems enables the flexible and rapid reconfiguration of a shared physical that is needed in today's secure networks while preserving the benefits of air gap architectures which use physical separation of network elements for security.

Glimmerglass Optical Cyber Solutions  
26142 Eden Landing Road  
Hayward, CA 94545 USA

Headquarters  
Phone: 877.723.1900  
In North America: 510.723.1900

Americas and Federal Sales  
Phone +1 510 723 1925  
Fax +1 510 780 9851

Middle East and Africa  
Sales  
Phone +1 510 461 2990  
Fax +1 510 780 9851

Asia-Pacific Sales  
Phone +852 2857 6308  
Fax +852 2857 6260

Europe Sales  
Phone +44 1590 636583  
Fax +44 1590 681308

[sales@glimmerglass.com](mailto:sales@glimmerglass.com)

**Glimmerglass**   
*Optical Cyber Solutions*